

Transfer or duplication of this document as well as the utilization or communication of its contents are prohibited unless explicitly authorized. All rights reserved for patent, utility model or design registrations. 非经书面授权, 复制或传播, 或向第三方提供, 或向媒体公开, 或向媒体发布, 或向媒体转载, 均属侵权行为。 一经发现, 本公司保留追究法律责任。 侵权者将承担全部法律责任。

未注公差/General tolerances(mm)											0.1/10		
0	>3	>6	>10	>18	>30	>50	>80	>120	>180	>250			
~3	~6	~10	~18	~30	~50	~80	~120	~180	~250	~315	~400	~500	>500
±0.12	±0.18	±0.22	±0.26	±0.31	±0.37	±0.57	±0.80	±0.93	±1.05	±1.15	±1.60	±2.20	±2.50

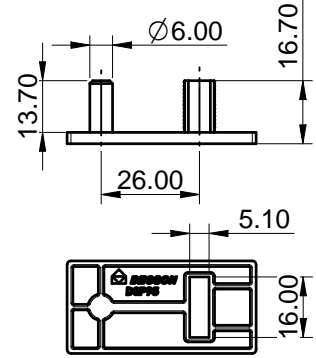
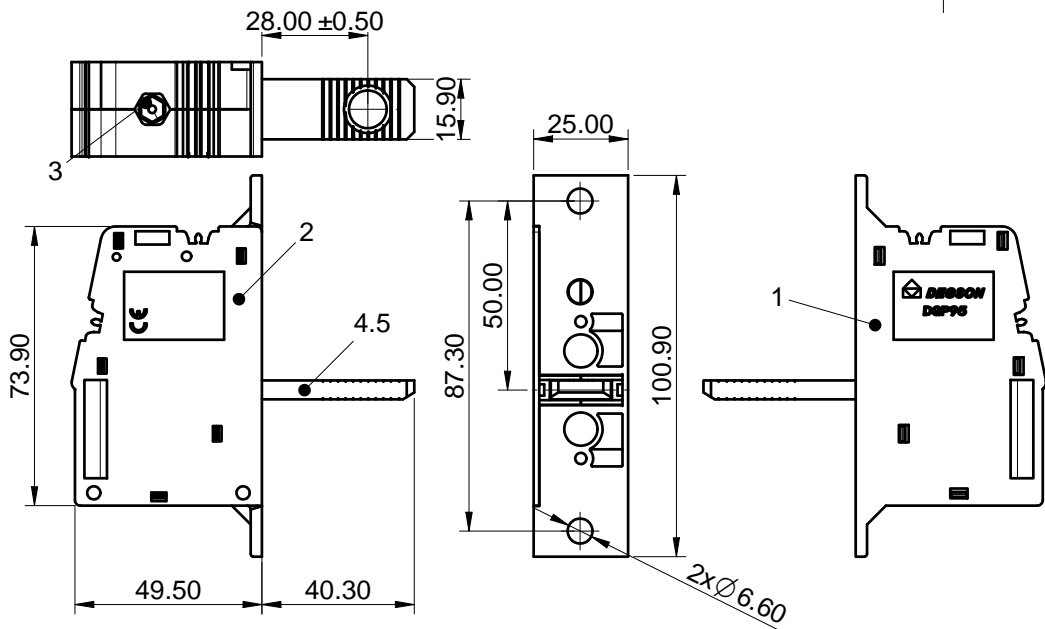

Note: The A&Z(H) in the name means: A(H) and Z(H).

ITEM	NAME OF PART	MATERIAL	NOTES
9	Antivibration Pad	EVA	Black
8	Lock Washer	Steel	Zn Plated
7	Screw 2	Steel	Zn Plated
6	Housing 3	PA66	UL94V-0
5	Groupware	/	Zn Plated
4	Current carrier	Copper	Sn Plated
3	Screw1	Steel	Zn Plated
2	Housing 2	PA66	UL94V-0
1	Housing 1	PA66	UL94V-0

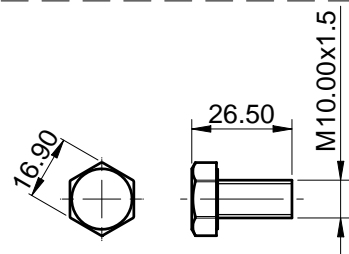
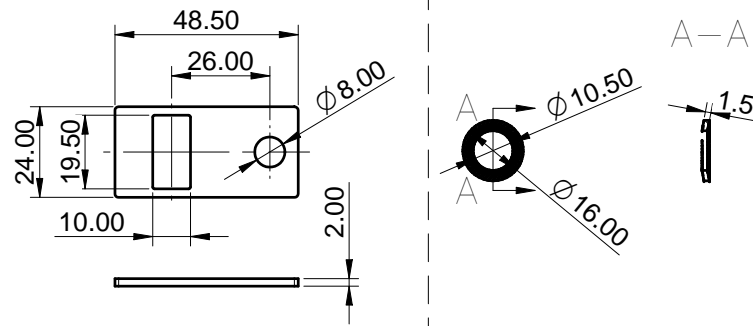
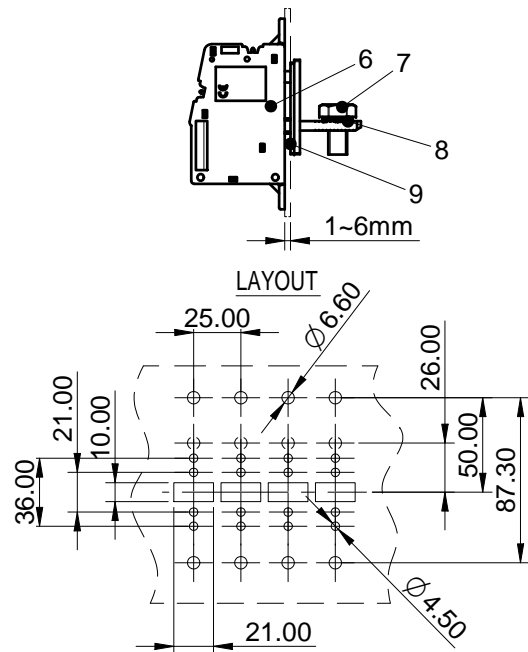

UL 标准/UL Standard:	B	C	D
额定电压/电流/Rated Voltage(V)/Current(A)	600/230	/	/
IEC 标准/IEC Standard:			
过压类别/Overvoltage Category/污染等级/Pollution Degree	III/3	III/2	II/2
额定电压/电流/Rated Voltage(V)/Current(A)	1000/232	/	/
额定脉冲电压(KV)/Rate Impulse Voltage(KV)	8	/	/
螺丝扭矩/Torque Tightening(N·m/Lb.in)	M8, 15/132.9 M10, 4.0/35.5		
线径范围(硬线和软线)/Wire Range(rigid and flexible)(AWG/mm ²)	4~4/0 / 25~95		
间距/Pitch(mm)/线数范围/Poles	25/N=01P		
剥线长度/Stripping length(mm)	27		
使用温度范围/Operating temperature(°C)	-40~+105		
符合 RoHS 环保要求/Conform to RoHS	Yes		

DEGSON		MATERIAL:	SURFACE:
APPD: 蓝贵凡	2022.12.2	MAT NO./REV: - / 00	MAT STATUS: 批量
CHKD: 曹利彬	2022.12.2	NAME	
DRFT: 虞倩松	2022.12.2	DGP95-01P-1Y-00A&Z(H)	
DRWING NO. 200018222	TYPE CUSTOMER DRAWING	DRAWING STATUS 已发布	SCALE 2:1
SHEET 1/1			

REV	ECN	DESCRIPTION	DRFT	DATE
00			设计人	设计日期

