

PCB LAYOUT

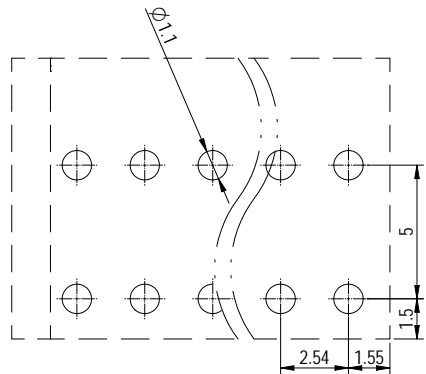

公差/General tolerances(mm)											0.1/10		
0	>3	>6	>10	>18	>30	>50	>80	>120	>180	>250	>315	>400	D Z
~	~	~	~	~	~	~	~	~	~	~	~	>500	
3	6	10	18	30	50	80	120	180	250	315	400	500	
±0.12 ±0.18 ±0.22 ±0.26 ±0.31 ±0.37 ±0.57 ±0.80 ±0.93 ±1.05 ±1.15 ±1.60 ±2.20 ±2.50											±2'		

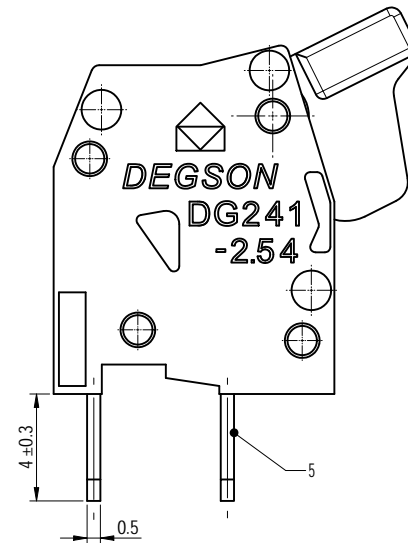
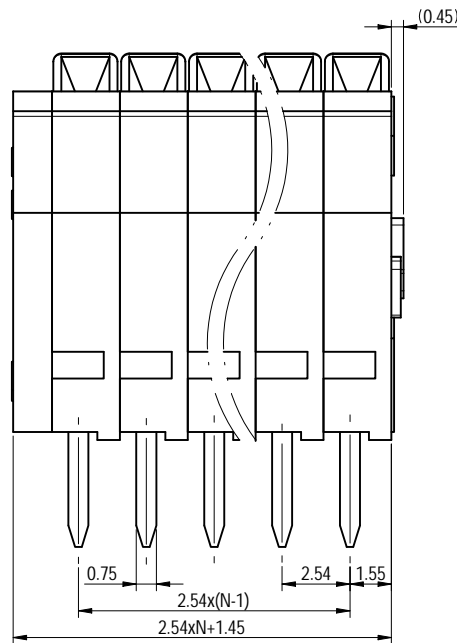
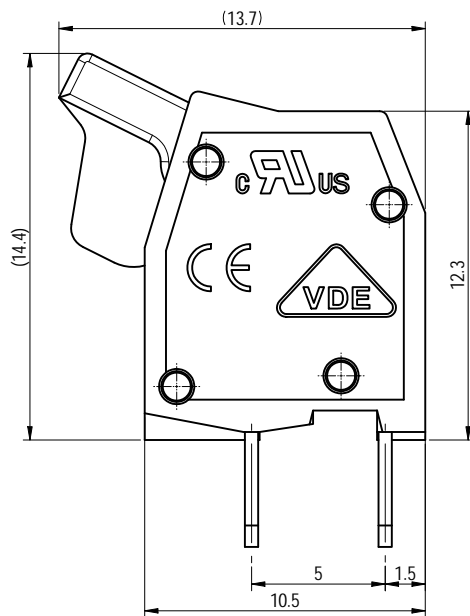
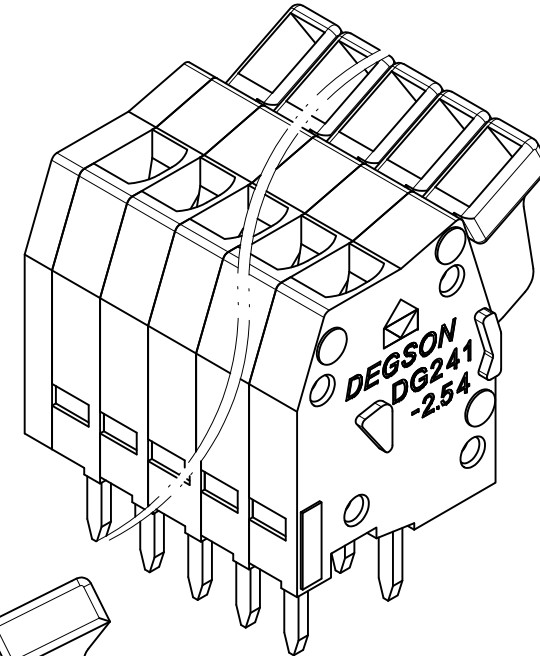
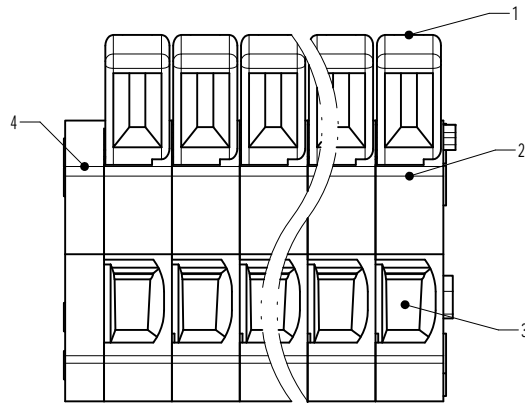

Note:  
The A&Z(H) in the name means: A(H) and Z(H).

ITEM	NAME OF PART	MATERIAL	NOTES
5	Pin Header	Copper Alloy	Sn Plated
4	Cover	PA66	UL94V-0
3	Spring	Stainless Steel	/
2	Housing	PA66	UL94V-0
1	Button	POM	UL94HB

UL 标准/UL Standard:	B	C	D
额定电压/电流/Rated Voltage(V)/Current(A)	150/5	/	/
IEC 标准/IEC Standard:			
过压类别/Overvoltage Category/污染等级/Pollution Degree	III/3	III/2	II/2
额定电压/电流/Rated Voltage(V)/Current(A)	63/6	160/6	320/6
额定脉冲电压 (KV) /Rate Impulse Voltage (KV)	2.5	2.5	2.5
线径范围(硬线和软线)/Wire Range(rigid and flexible)(AWG/mm²)	28~20/ 0.2~0.5		
间距/Pitch(mm)/线数范围/Poles	2.54/N=01~27P		
剥线长度/Stripping length(mm)	5~6		
使用温度范围/Operating temperature(°C)	-40~+105		
符合RoHS环保要求/Conform to RoHS	Yes		

**DEGSON** MATERIAL: / SURFACE/COLOR: /  
 MAT NO./REV: - / 00 MAT STATUS: 批量

APPD: 兰春华 2023.02.07 NAME  
 CHKD: 陈超 2023.02.07  
 DRFT: 智学龙 2023.02.06

DWG NO. 200025617 TYPE CUSTOMER DRAWING DRAWING STATUS 已发布 SCALE 5:1 SHEET 1/1

物料号 2023.02.06  
 DATE

REV	ECN	DESCRIPTION	DRFT	DATE	00
00				2023.02.06	

Transfer or duplication of this document as well as the utilization of its contents in any form without the written permission of DEGSON is prohibited. All rights reserved for patent. 复制或再行发布此文件以及其内容以任何形式的使用，未经 DEGSON 书面许可，均被禁止。保留所有权利。 专利侵权必究。