

Transfer or duplication of this document as well as the utilization or communication of its contents are prohibited without the written permission of DEGSON. All rights reserved for patent. 除专利声明外，其他任何内容的复制或传播均受法律保护。未经授权，禁止复制或传播本文件中的任何内容。本公司保留对本文件的所有权利。

未注公差/General tolerances (mm)												0.1/10 ±2'	
0	>3	>6	>10	>18	>30	>50	>80	>120	>180	>250	>315		>400
~3	~6	~10	~18	~30	~50	~80	~120	~180	~250	~315	~400	~500	~500
±0.12	±0.18	±0.22	±0.26	±0.31	±0.37	±0.57	±0.80	±0.93	±1.05	±1.15	±1.60	±2.20	±2.50

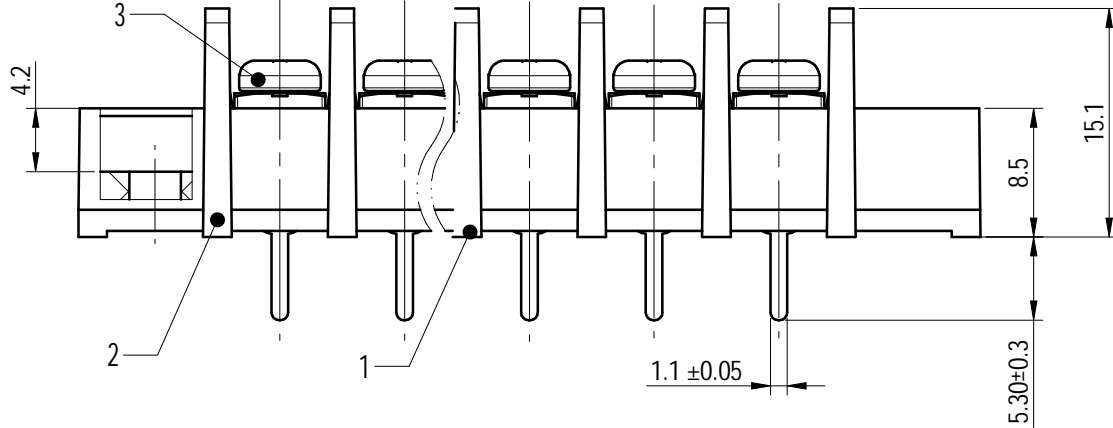
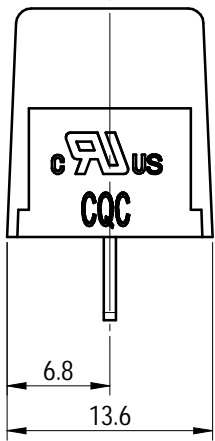
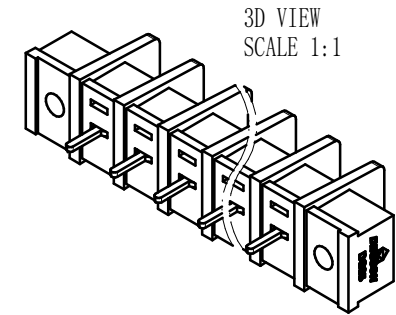
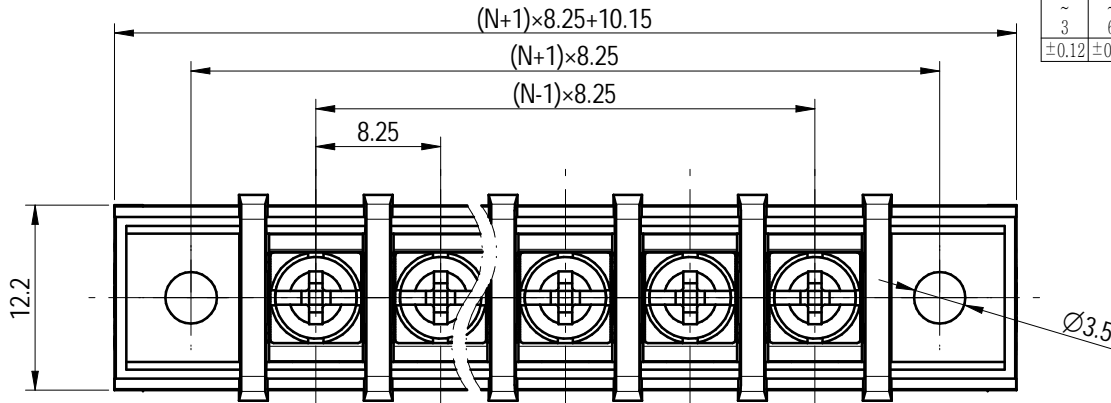

Notes: The A&Z (H) in the name means: A(H) and Z(H)

ITEM	NAME OF PART	MATERIAL	NOTES
3	Screw	Steel	Ni Plated
2	Pin header	Copper alloy	Sn Plated
1	Housing	PA66	UL94V-0

UL 标准/UL Standard:	
额定电压/电流/Rated Voltage(V)/Current (A)	300/20(B)
IEC 标准/IEC Standard:	
额定电压/电流/Rated Voltage(V)/Current (A)	450/32
螺丝扭矩/Torque Tightening(N · m/Lb.in)	M3, 0.5/4.43
线径范围(硬线和软线)/Wire Range(rigid and flexible)(AWG/mm ²)	22~12 / 4.0
间距/Pitch(mm)/线数范围/Poles	8.25/N=02~24P
使用温度范围/Operating temperature(°C)	-40~+105
符合 RoHS 环保要求/Conform to RoHS	Yes

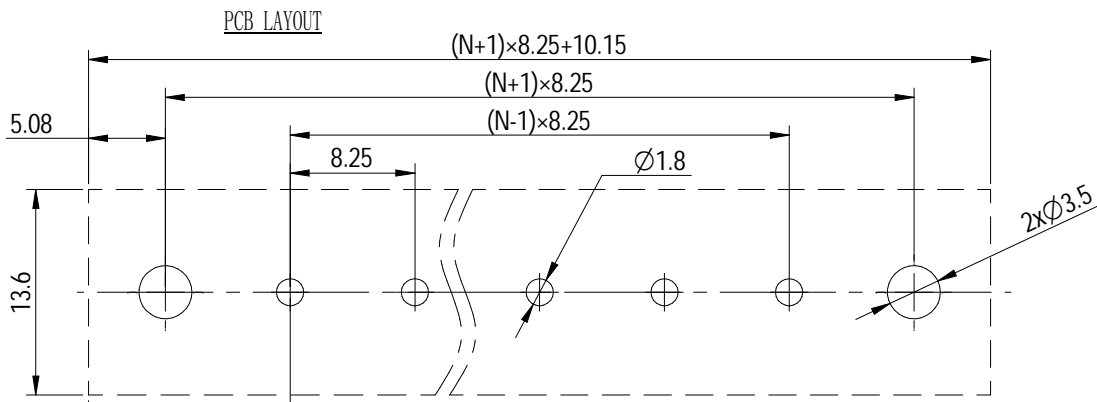

DEGSON		MATERIAL: /	SURFACE/COLOR: /	
APPD: 蓝贵凡 2024.10.23		MAT NO./REV: / / 00		MAT STATUS: 批量
CHKD: 朱伟明 2024.10.23		NAME		
DRFT: 汪德荣 2024.10.23		DG35C-A-XXP-1Y-00A&Z(H)		
DRAWING NO.	TYPE	DRAWING STATUS	SCALE	SHEET
200058484	CUSTOMER DRAWING	已发布	2:1	1/1

REV	ECN	DESCRIPTION	DRFT	DATE
00			汪德荣	2024.10.23