



Photoelectric Sensors
DPSN/DPSJ

User Manual

Thank you for choosing Degson products. Please read this instruction manual carefully before using the product.

- It is intended to be used by personnel with certain electrical knowledge.
- Before using this product, please read this manual carefully and use it correctly after fully understanding the product.
- For your convenience, please keep this manual properly so that you can refer to it at any time.

symbol

The following symbols are important reminders in this manual. Please be sure to comply with the following.

	There is a risk of malfunction or fire. Please do not exceed the rated voltage when using.
	Do not use AC power as there is a risk of rupture.
	There is a risk of burns due to high temperatures.

Safety Tips

To ensure your safety, please be sure to follow the following.

- Do not use in an environment with flammable or explosive gases.
- Do not use the product in an environment with water, oil, chemical droplets, or in contact with steam.
- Do not disassemble, repair, or modify the product without authorization.
- Do not exceed the rated voltage and current range during use.
- Do not use in environments beyond the rated value.
- Please pay attention to the polarity of the working power supply and do not connect the wrong wires.
- Please connect the load correctly.
- Do not short-circuit the load.
- Do not use if the casing is damaged.
- When disposing of it, please treat it as industrial waste
- Do not use in direct sunlight.
- Due to the use conditions (ambient temperature, power supply voltage, etc.), the sensor surface temperature may rise. Please be careful when operating or cleaning it, as there is a risk of burns.

Instructions for use

- Do not use in the following places
Locations exposed to direct sunlight
Places with high humidity and easy condensation
Places containing corrosive gases
Locations where vibration and shock are directly transmitted to the product body
- When the lead wires of this product are installed in the same conduit as the power wires and electric power wires, they may be interfered with, malfunction or even be damaged.
- Extension cables must have a cross-sectional area of 0.3mm² or more and a length of 100m or less. When using Korean S-mark certified models as certified products, please set the length to 10m or less.
- The forces applied to the conductors are as follows: tension less than 40 N, torque less than 0.1 N·m, pressure less than 20 N, bending less than 3 kg.
- After the power is turned on, the product is in a detectable state within 200ms. Therefore, if the load and the product are connected to different power supplies, the power of the product must be turned on first
- After cutting off the power supply, output pulses may occur, so please cut off the power supply of the load or load line first.
- Please do not use solvents such as thinner, gasoline, acetone, kerosene, etc. to clean.

Confirmation of packaging contents

- sensor One (one pair)
- User Manual One
- Mounting Screws One set (PTN)

Technical specifications

type	DPSN Series	
model	DPSN-D05N(P)	DPSN-T50N(P)
Detection method	Diffuse	Opposed beam
Detection distance	5cm	50cm
Switch mode	L.on (light on)	D.on (light blocking action)
Output Mode	NPN/PNP open collector	
Response time	≤1 ms	
Operating voltage	12~24V DC±10%	
Outlet mode	Φ2.4*2M/3 core wire	(Receiving end) Φ2.4*2M/3 core wire (Transmitter) Φ2.4*2M/3 core wire
Protection Circuit	Power reverse connection protection and output short circuit protection	
Protection level	IP64	

type	DPSJ Series	
model	DPSJ-T80 \square -1	DPSJ-T150 \square -1
Detection method	Shooting	
Detection distance	80cm non-adjustable	150cm non-adjustable
Switch mode	L.on (light-on action) / D.on (light-off action) models are available	
Output Mode	NPN/PNP open collector	
Response frequency	150HZ	
Operating voltage	12~24V DC	
Protection Circuit	Reverse polarity and short circuit protection	
Protection level	IP64	

* \square NPN normally open \square NPN normally closed \square PNP normally open \square PNP normally closed

Circuit Diagram

DPSN Series

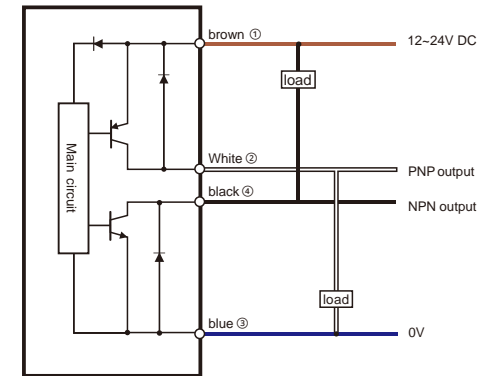

DPSJ Series

NPN output

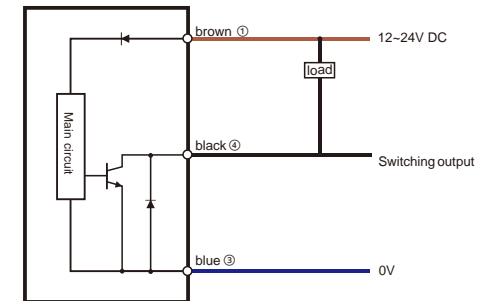

PNP output

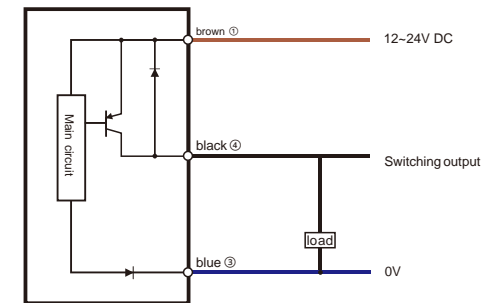

Dimensions

DPSN

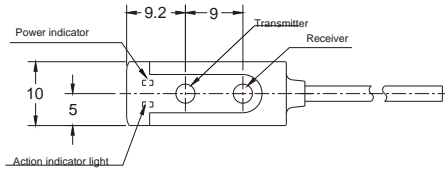
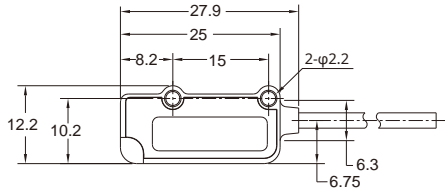

DPSJ

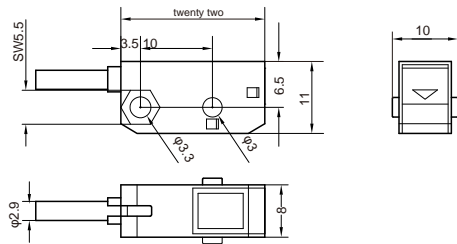

Installation

Through-beam type

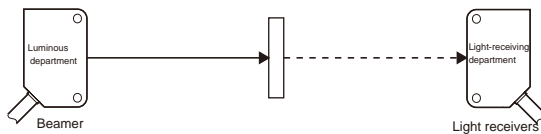

Diffuse reflection

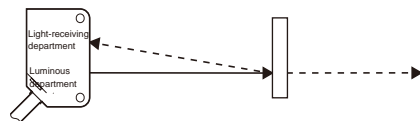

Power Distribution Considerations

Supply voltage

Do not use the product beyond the voltage range. Inputting voltage beyond the range or inputting AC power into a DC power type may cause the product to rupture or burn out.

Load short circuit

Do not short-circuit the load to avoid rupture or burning. The load short-circuit holding function is a function used within the rated voltage with the correct polarity of the power supply.

Miswiring

Do not mismatch the polarity of the power supply, as this may cause rupture or burning.

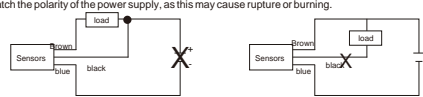

When no load is connected

If the power supply is directly connected to the internal element without a load, it may cause cracking or burning. Therefore, please add load before wiring.

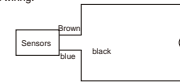

Regular maintenance checks

During the use period, regular inspection and maintenance are very necessary to ensure the normal operation of the machine.

The regular inspection items are as follows:

- When detecting an object, whether the switch is within the distance, whether it is loose, whether it is tilted, and whether the detected object has changed.
- Whether the wiring or connecting wires are in normal contact or there is no concern about disconnection.
- Whether there is dust on the sensing surface.
- Check whether the operating temperature and surrounding environment are normal.
- Check the installation space for any abnormalities, such as vibration, electrical leakage, etc.

other:

After power is turned on, the sensor needs a lead time of 100ms to achieve stable output of the sensor. Therefore,

do not operate the sensor during this period. Avoid using it outdoors (except when there is a shield).

- Avoid direct contact with organic solvents.
- Avoid objects hitting the detection surface, as the sensing surface is very fragile.
- Do not pull or move the power supply excessively during installation or movement.



Precautions

- Please make sure that the power is off when wiring.
- Please confirm that the power supply voltage varies within the rated range.
- If the power is provided by a commercial switching regulator, make sure that the frame ground terminal (FG) of the power supply is connected to ground.
- Be sure to connect the equipment ground terminal (FG) to ground.
- Do not use the device within a short period of time (0.5s) after the power is turned on.
- Do not run the wiring together with high voltage or power lines or in the same conduit as this may cause malfunction due to induction.
- Avoid dust, dirt and water vapor.
- Do not put the sensor in direct contact with water, oil, grease or organic solvents such as thinners.

Product Commitment

Degson's products undergo strict factory inspection. If a fault occurs, please contact the nearest Degson office and provide detailed information so that we can solve it as soon as possible.

Warranty

- The product warranty period is one year, starting from the date the product is shipped to the place designated by the purchaser.

Warranty coverage

- (1) If a fault occurs during the warranty period stated above and caused by Degson, Degson will repair the product free of charge. However, the following situations are not covered by the warranty.
- Failure caused by improper operation or improper use under the conditions or environment not specified in the operating instructions, user manual or technical requirements specially agreed upon between the purchaser and Degson
 - The failure is not due to a product defect but is caused by the design of the purchaser's equipment or software.
 - The failure is caused by modification or repair performed by someone other than Degson.
 - Failures that can be completely avoided by properly repairing or replacing wearing parts in accordance with the operating instructions or user manual.
 - Failures caused by unforeseen changes in the level of science and technology after the product is shipped from Degson.
 - Failures caused by natural disasters such as fire, earthquake and flood, or external factors such as abnormal voltage are not covered by Degson
- (2) The warranty covers only the situations specified in Article (1). Degson shall not be liable for any indirect losses (damage to equipment, loss of opportunity, loss of profits, etc.) or other losses caused to the purchaser by its equipment.

Product Suitability

Degson's products are designed and manufactured as general-purpose products for general industries. Therefore, Degson's products must not be used for the following applications and are not suitable for their use. However, if the purchaser consults Degson in advance about the use of the product with a responsible attitude and understands the technical specifications, grades and performance of the product, and takes necessary safety measures, the product can be used. In this case, the product warranty scope is the same as above.

- Uses that may result in chemical contamination or electrical interference, or use under conditions or environments not described in the product catalog, instruction manual, etc.
- Atomic energy control equipment, incineration equipment, railway, aviation, vehicle equipment, safety devices, and administrative agencies and equipment manufactured in accordance with the regulations of individual industries.
- Machinery, systems and devices that may endanger life or property.
- Gas, water, and electricity supply systems require highly reliable equipment that operates continuously 24 hours a day.